

**REGEN**

**Rod Pump & Progressing Cavity Pump Applications**

The Lufkin Well Manager™ (LWM) integrated with a line regenerative variable speed drive (REGEN) control opens up new opportunities for low-maintenance control of rod pumps and progressing cavity pumps. The REGEN controller fully regenerates power back to the source when overhauling loads occur, eliminating the need for auxiliary braking resistors. The regenerated power is returned to the line to be used by nearby loads. The greatest benefits are achieved when multiple loads are connected to a single power meter.

It maintains a near-unity power factor with low harmonic content, eliminating the need for external harmonic filters while still passing the requirements of IEEE 519-1992 when operated at full load. The inherent direct torque control algorithms deliver full power to the pump at zero speed, but is also protective by providing torque limits to reduce mechanical stresses on the system.

The LWM with REGEN adjusts the pump rate to match the well's conditions on every stroke, based upon the previous stroke. This level of ease and control provides customers with peak production while reducing their maintenance and overall operating costs.

The REGEN controller is fully integrated through the LWM, eliminating the need for cumbersome setup. Everything is designed to make the operator's job easier. The LWM's Quick Start programming method allows the user to simply enter a few parameters to get the system up and running. Auto-tuning has never been simpler. The LWM takes over the task, eliminating the need to perform a motor disconnect and reconnect. Control and access to all of the LWM's features are available through the LWM keypad or SCADA interface.

Mechanical limits and difficult pumping applications can present real challenges with equipment down-time. The REGEN is developed with equipment protection and preservation in mind. By slowing a unit just enough to avoid working load violations, the REGEN can help manage rod float problems and peak rod load issues with heavy oil. The LWM continually monitors the equipment and production providing the best response when a malfunction is detected. In such an event, user presets stop the pumping unit or reduce the pump rate to a predefined minimum speed. These advanced features all work together to protect both your equipment and overall investment.

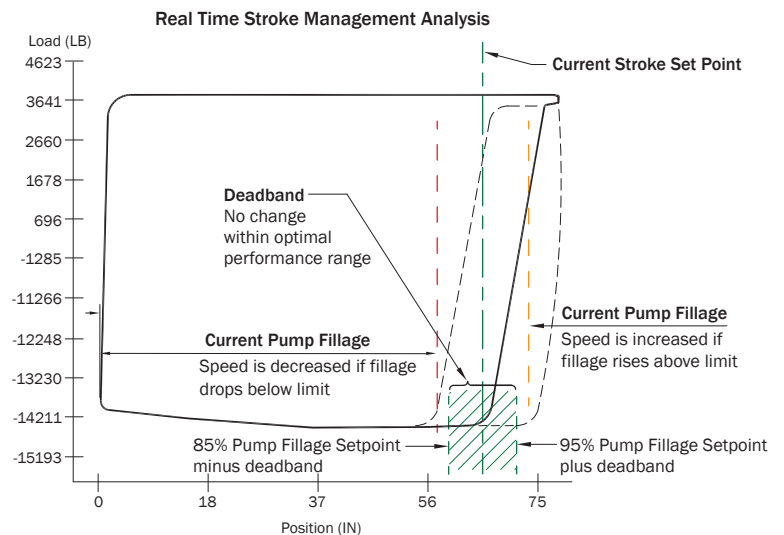

The LWM continually monitors, analyzes, records and adjusts the pump speed to match any variations within the well.

**Ideal for locations where:**

- ✓ Braking resistors pose a hazard
- ✓ Local power grid calls for cleaner power consumption
- ✓ External harmonic mitigation filters will not meet requirements
- ✓ Multiple pumps on one meter where energy can be used locally

# Advantages of REGEN

## Cleaner Incoming Power

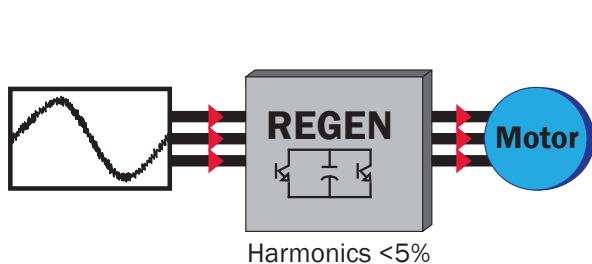

Harmonics <5%

Active Front End controllers such as the REGEN draw sinusoidal current resulting in a linear load.

The REGEN controller uses actively controlled transistors on the front end. These transistors are switched in sync with the sinusoidal line voltage resulting in a sinusoidal current input, keeping the harmonic content below 5%.

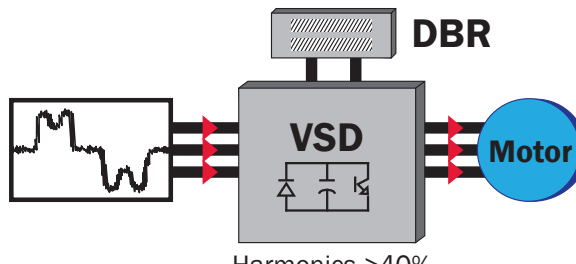

Harmonics >40%

Standard 6-pulse drive with a passive front end has non-sinusoidal current draw.

Standard 6-pulse VSDs use six diodes or SCRs on the line side. These passive devices only conduct in one direction and only when the incoming voltage is above the internal DC voltage. The power source sees 12 pulses of current while delivering power to the motor, resulting in a non-sinusoidal current waveform with harmonics well above 40%.

## Capture Regenerative Power

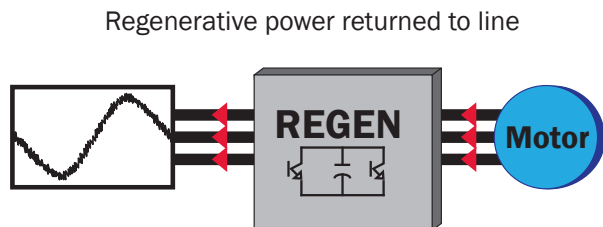

Regenerative power returned to line

When REGEN drives receive regenerative power from the load, they can return this energy back to the power grid for use in nearby loads.

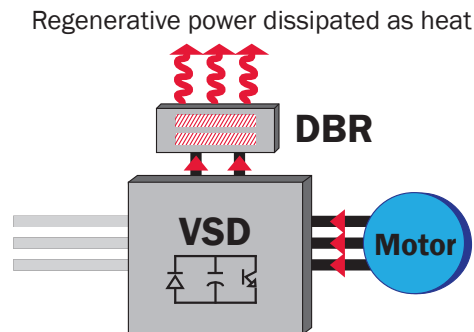

Regenerative power dissipated as heat

When 6-pulse drives receive regenerative power from the load, they must dissipate this energy as heat through dynamic braking resistors.

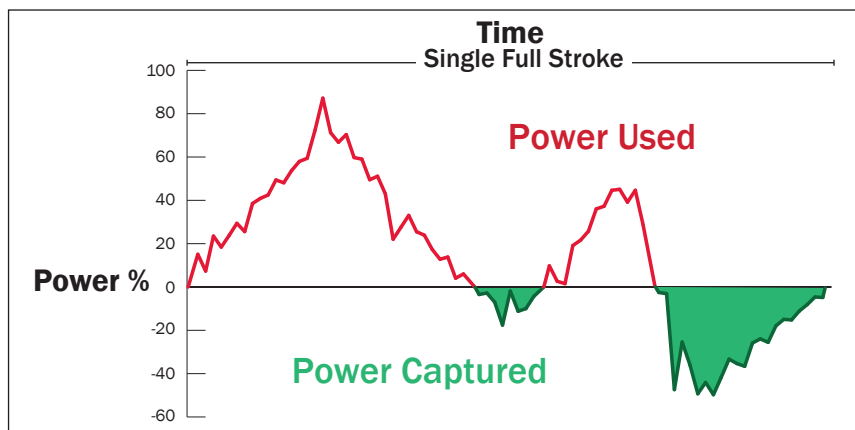

Typical power curve of a Mark II unit. Note the curve below the zero line is regenerative power being captured and returned to the line (green areas) by the REGEN controller.

## Rod Pump & PCP Applications

### Features & Benefits

- **Eliminate high-maintenance resistor banks** – Line regenerative controls capture energy created during negative torque cycles of the stroke to return power to the grid instead of requiring it to be burned off in resistor banks.
- **Cleaner power** – 6-pulse drives draw peak currents up to 12 times per cycle. This results in a non-sinusoidal waveform and the creation of harmonics. Line regenerative controls actively switch the power source in a method that results in a linear loading on the power system.
- **Meets IEEE 519-1992 at full load** – The line regenerative control when operating at full load meets the specification of IEEE 519-1992 regardless of incoming voltages and/or imbalances. Many other multi-pulse configurations (12-pulse, 18-pulse) cannot accomplish this unless the voltages are symmetrical.
- **Easier starting power** – Using Direct Torque Control (DTC) algorithms within the drive, the REGEN controller gives full torque at zero speed resulting in easier starts.
- **Smart bypass system** – The LWM constantly monitors the REGEN controller for any events and responds intelligently. Critical faults on the REGEN result in auto-bypass without the need for intervention.
- **Rod float mitigation** – The unit is slowed on the downstroke to maintain a minimum weight on the rod pump to eliminate rod float.
- **Configuration flexibility.** The LWM REGEN is an intelligent control system that integrates smoothly with RPC or PCP. This combination replaces the traditional contactor box and provides everything in one enclosure.
- **Factory-tested integration.** The Lufkin combined package of the LWM and the REGEN in the same cabinet has been fully integrated and tested for compatibility. The combined package, with enhanced features, provides for simpler field installation, better service support and an assurance that the pre-wired, factory-tested cabinet has already addressed any interference issues.
- **Simplified setup.** Setup is simplified because most parameters are properly defaulted. Only items such as motor parameters need be entered.
- **Optional heater kit.** For cold climates, the LWM REGEN features a thermostat-controlled heater.
- **Connect to existing NEMA D or B motors.** The REGEN can operate an existing induction motor, thereby reducing installation costs associated with purchasing a new motor.
- **Optimized production and pumpdown.** Downhole or surface pump fillage is the basis for controlling speed to optimize production and pumpdown. The normal speed control algorithm is based on a programmed starting speed, and increases or decreases in speed are determined on every stroke from the dynamometer pump card.
- **Programmable upstroke/downstroke speed.** Downstroke speed can be programmed as a percentage change from the upstroke speed, and the point in the stroke at which the speed change occurs is also programmable.
- **Working-load limits for speed limiting.** If a peak or minimum working-load limit is exceeded (e.g., due to paraffin buildup or low flowline temperatures), the normal pump-fillage-speed control is overridden, and the speed is reduced in steps. On each stroke that a violation occurs, the speed is slowed an additional increment, until the violation no longer occurs. In this manner, production is optimized within the mechanical load limits established by the operator.
- **Stop on malfunction or run at minimum speed.** If any of the safety-limit violations occur, the operator has the option to continue operating at minimum speed or to stop the pump. When stopped or running at minimum speed, the unit is placed in a downtime state for the programmed downtime period. When that period expires, the unit will attempt to start up normally.
- **Peak-power limiting (programmable peak torque).** In a steam-flood or steam-cyclic operation, the well cools with time, and the peak load and peak power increase with time. The LWM can be programmed with an overall peak-torque limit to protect equipment (e.g., from thermal motor overloads) and keep it operating within the limits of the system.
- **Convenient Modbus master programming and monitoring.** A keypad and LCD give the operator a way to program and monitor REGEN via the LWM unit which is capable of Modbus master communications, using RS-485. This has been customized for the Lufkin REGEN application so that all normal drive programming can be accomplished through the LWM keypad, or via host, thereby providing a unified interface.
- **Speed plot for 24 hours (1 minute sampling).** Speed changes during the day can be viewed with the 24-hour speed plot to view production optimization effectiveness.



**General Specifications**

- 2500+ status registers (e.g., SPM, peak/min. load, RPM, pump fillage)
- Inferred production tracking (today, 60-day history, programmable oil cut, account for pump leakage)
- Graphical LCD with keypad
- Surface and downhole dynagraph cards
  - Real time
  - 5 recent stored cards
  - Startup card
  - Pumpup card
  - Last two shutdown card groups (5 cards each)
  - Standard card
- Standard LWM communication (laptop, radio, cell phone)
- Standard 60-day plots (inferred production, runtime, peak/min. loads, polished rod horsepower)
- Last 400 point load plot
- Accurate polished rod load cell or beam transducer load Input
- Accurate motor/crank hall-effect or inclinometer position Input
- Valve check/pump leakage diagnostic
- Notepad
- Advanced RTU features
  - Expanded I/O capability (w/alarms)
  - Logic expression
  - Register logging
  - Register digital output/alarms
  - Register calculator
  - AGA 3/NX-19 gas flow calculation
  - Well state alarms and logging
  - Accumulator support

- Event logs (time stamped events, shutdown log, and alarm log)
- Coil tracking
- Complete unit can replace an existing contactor box or be used by itself for motor control on a new installation.

REGEN Specifications		
Power Rating		20-125 HP, 15-93 kw
Power Supply	Rated Voltage/ Frequency	460 V class: 3-phase, 50/60 Hz
	Voltage Tolerance	+15%, -20% (340-550V)
	Frequency Tolerance	48 to 63 Hz
Rated Output	Voltage	460 V class: 0 to max Input voltage
	Frequency	0 to 300 Hz
Overload Current Rating		150% for 60 seconds, 170% for 10 seconds
Regen Braking		Full line regenerative without the need for braking resistors
Motor Control		Direct Torque Control (DTC) or V/Hz
Speed/Torque Control		Unique LWM to VSD control algorithm
Ambient Temperature/ Relative Humidity		-40 to 55C, 0-95% relative humidity, non-condensing
Protection		Built-in surge protection that meets UL 1449, Rev 3
Cooling Method		Forced Air
Harmonic Content		Meets IEEE 519-1992 at full load
Motor Tuning		Static autotuning. Decoupling of the motor is not required.
Enclosure		NEMA 3R

# Rod Pump & PCP Applications

## Real-Time Dynagraphic Cards

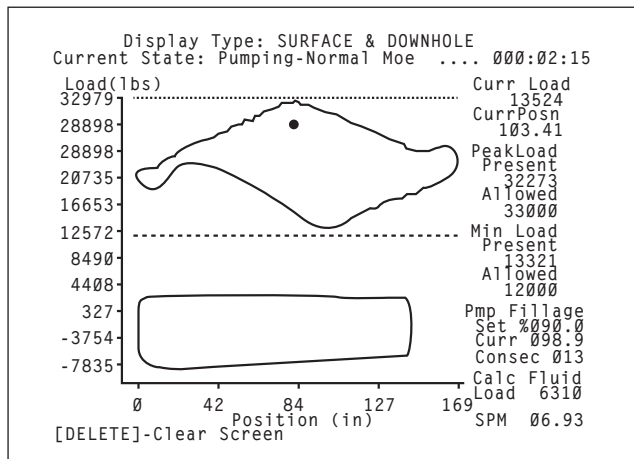

## Sample Status Screen

RPC Ver. 6.14 CS: 06206EC1 07-25-2011 14:02  
RPC Status Screen

RTU Address 0145  
Current Well State Pumping-Normal Mode  
Elapsed Time 000:07:17  
Control Mode VSD-DH  
Operation Mode Normal  
Minimum Pump Strokes 005  
Downtime 000:05(hh:mm)

Guage Off Time(GOT) 00:00  
Run Yesterday 100 % 24:00 (hh:mm)  
Run Since GOT 099 % 14:10 (hh:mm)

Liquid	Oil	Water	TBGas
bb1s	bb1s	bb1s	mscf
SWT Since GOT 0149.8	0134.9	0014.9	112.5
Yesterday SWT 0235.7	0212.2	0023.5	172.8
Inst SWT (per day) 0277.7	0250.0	0027.7	175.7
Projected SWT (per day) 0251.0	0225.9	0025.1	188.6

Pump Fillage 089.57 %  
Pumping Speed 06.94 spm  
VFD Speed Command 0050.0 Hz  
VFD Output Speed 049.93 Hz

LUFKIN AUTOMATION [NEXT] Next Screen

## Average SPM

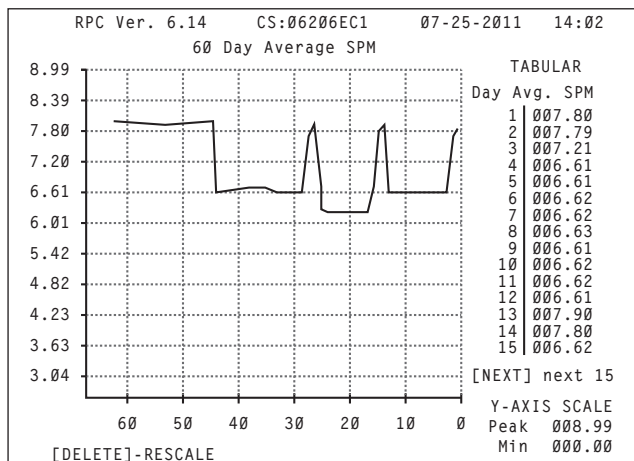

## Quick Start

RPC Ver. 6.14 CS: 0655DECA 07-25-2011 14:02  
VSD PARAMETERS

VSD Drive Type ACS 800  
Speed Output A01  
Maximum Speed (RPM) 1800  
Minimum Speed (RPM) 0000  
Deadband +/- 005.00  
Speed Change Stroke Delay 001  
Start Up Speed (% of Full Scale) 020  
Speed Increase Size (% of Full Scale) 005  
Speed Decrease Size (% of Full Scale) 005  
Working Peak Load Limiting (lbs ) 50000  
Working Min Load Limiting (lbs ) 0  
Working Peak Speed (RPM) 1200  
Working Min Speed (RPM) 0600  
Protection DT/Malfunction Control RUN LOW SPEED

Enable Disable Up/Down Stroke Speed DISABLED

[NEXT]-Next Screen  
LUFKIN AUTOMATION Tel. No. (281)-495-1100



Access to accurate well data is right at your fingertips.

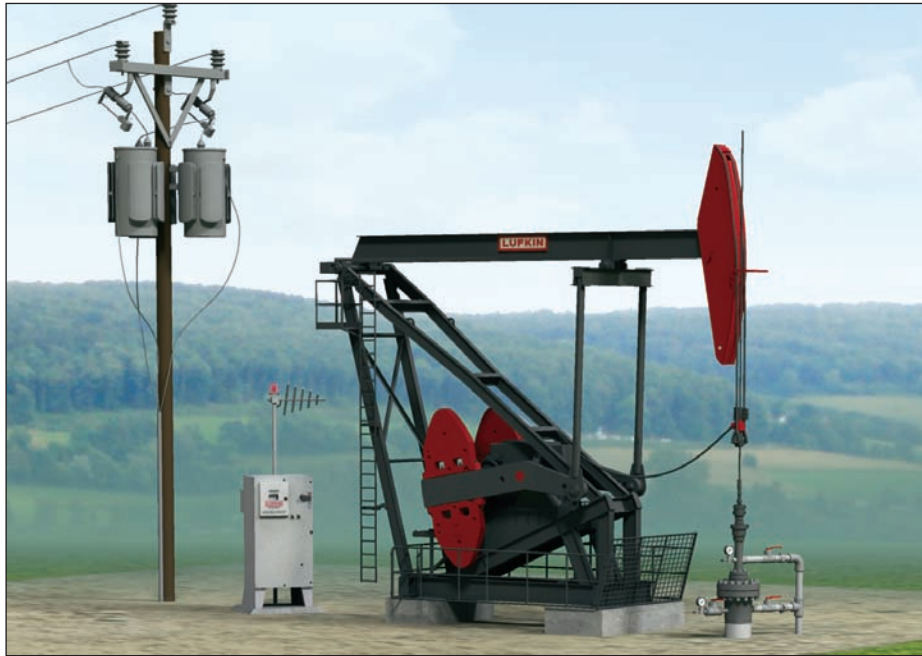

## LWM Rod Pump Control Accessories

Lufkin Automation offers RPC transducers to work with the LWM for all the different pumping unit types. The transducer selection allows the user to choose the accuracy of the system

and consider the long-term maintenance requirements. Each transducer is designed to interface with Lufkin RPCs and is manufactured to Lufkin's quality standards.



Standard Load Cell

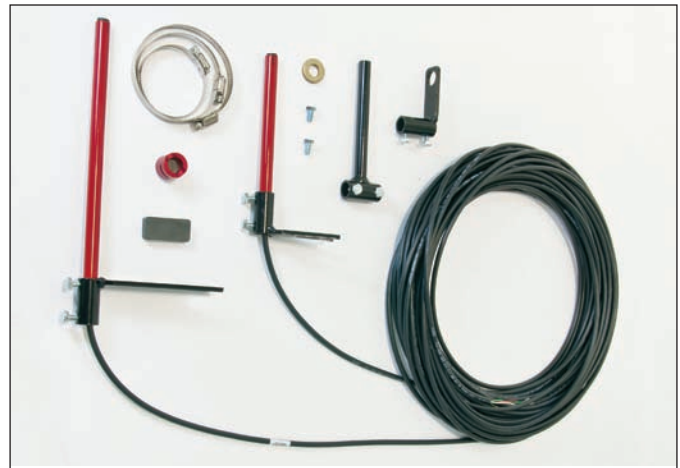

Motor and Crank Hall Effect Transducers

## Contact Lufkin Automation

[Lufkin.com/Automation](http://Lufkin.com/Automation)

### Automation Headquarters

811 Willow Oak Drive  
Missouri City, Texas 77489  
(800) 504-1184  
(281) 495-1100  
Fax: (281) 495-6333

E-mail [automation@lufkin.com](mailto:automation@lufkin.com) for additional locations and information.